

# COMMERCIAL & LIGHT INDUSTRIAL IMMERSION HEATERS

## Description

The HR range of immersion heaters are designed for commercial and light industrial applications. The rotatable terminal box is provided for ease of wiring and flexible for access in all types of locations. Along with the standard range detailed below, we also manufacture using different levels of element sheath protection, depending on the environment the heater is being installed into.

## Key features

- For use in water, in commercial/light industrial applications
- IP55 rotatable terminal cover
- Incoloy 825 sheath
- Single thermostat pocket
- Separate power and control glands
- Large range of thermostats available
- Unique design offers both single and three phase installation
- Loading: 3-12kW
- Element diameter: 8mm
- Temperature range: 28-80°C control, 90°C cutout
- Voltage: 415V 3-Phase , 240V 1-Phase
- Optional: Supplied with or without thermostat
- Other: Alternative mounting option available



HR Light Industrial Immersion Heater

## Technical specification

Part Number			Loading (kW)	Voltage (V)	Phase Connection	Immersed Length (in/mm)
2 ¼" BSP	2" BSP	1 ¾" BSP				
HR311A	HR311B	HR311C	3	240/415	1/3 PH	11/280
HR616A	HR616B	HR616C	6	240/415	1/3 PH	16/406
HR624A	HR624B	HR624C	6	240/415	1/3 PH	24/609
HR636A	HR636B	HR636C	6	240/415	1/3 PH	36/914
HR916A	HR916B	HR916C	9	415	3 PH	16/406
HR924A	HR924B	HR924C	9	415	3 PH	24/609
HR936A	HR936B	HR936C	9	415	3 PH	36/914
HR1224A	HR1224B	HR1224C	12	415	3 PH	24/609
HR1236A	HR1236B	HR1236C	12	415	3 PH	36/914

Temperature range: 28-80°C, cut-out 90°C

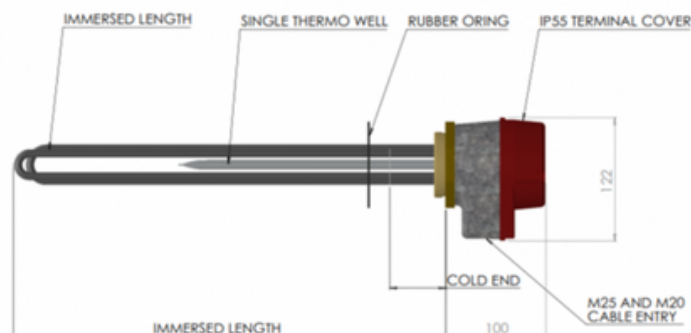

Bespoke designed industrial immersion heaters available on request. Please do not hesitate to contact us.